

## Indexable Milling Tools

### BCF-TE | Roughing Ball - Taper Necked Long Shank

<b>Q max</b> High Efficient	<b>▽</b> Roughing	<b>▽▽</b> Semi-Finishing	<b>HRC</b> 50	<b>No. of Teeth</b> 2
--------------------------------	----------------------	-----------------------------	------------------	--------------------------

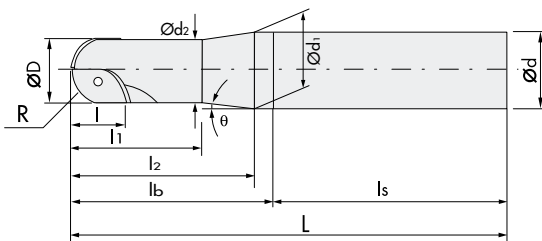
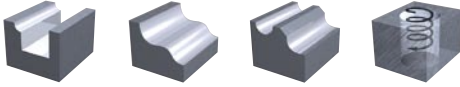

R	±0.05
ØD	0/-0.15

ID Code	Item Code	Flutes	ØD	R	L	Ød	l	l <sub>1</sub>	l <sub>2</sub>	l <sub>b</sub>	l <sub>s</sub>	θ°	Ød <sub>1</sub>	Ød <sub>2</sub>	Inserts x1	Inserts x1
FH035	<b>BCF-2018S25TE</b>	2	20	10	250	25	18	30	72	80	170	3°	23.4	19	ZCEW100CE*	ZCEW100SE*
FH036	<b>BCF-2018S32TE</b>		25	12.5	300	32	23	35	97	105	185	4°9'	31.2	18	ZCEW100CE*	ZCEW100SE*
FH041	<b>BCF-2523S32TE</b>		30	15	350							2°8'	30.1	24	ZCEW125CE*	ZCEW125SE*
FH045	<b>BCF-3028S32TE</b>		32	16	350	32	28	40	92	100	250	1°3'	31.2	28.8	ZCEW150CE*	ZCEW150SE*
FH386	<b>BCF-3228S32TE</b>		0°3'	30.6	ZCET160CE							ZCET160SE				

\* or ZCET Inserts: p. 11



Parts	Clamp Screw		Wrench	
Body	ID-Code	Item-Code	ID-Code	Item-Code
<b>BCF-2018S25TE</b>	ET034	<b>261-141</b>	ET011	<b>104-T10</b>
<b>BCF-2018S32TE</b>	ET034	<b>261-141</b>	ET011	<b>104-T10</b>
<b>BCF-2523S32TE</b>	ET035	<b>262-141</b>	ET012	<b>104-T15</b>
<b>BCF-3028S32TE</b>	ET036	<b>263-141</b>	ET014	<b>105-T20</b>
<b>BCF-3228S32TE</b>	ET036	<b>263-141</b>	ET014	<b>105-T20</b>

## Indexable Milling Tools

### INSERTS | Roughing Ball

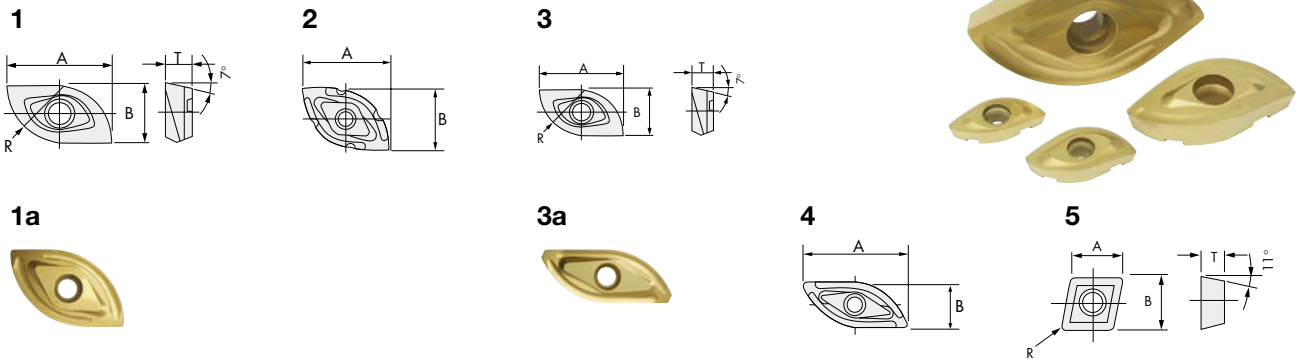

ID Code	Item Code	Grade	C-Coated		G-Coated	R	l(A)	T	W(B)	Figure
			CY250	CY9020	HC844					
WF583	<b>ZCET100CE</b>	CY9020		■		10	18.3	4.74	10	1a
WF132	<b>ZCEW100CE</b>	HC844			■					1
WF588	<b>ZCET100SE</b>	CY9020		■			16.7	4.24	8.1	3a
WF135	<b>ZCEW100SE</b>	HC844			■					3
WF584	<b>ZCET125CE</b>	CY9020		■		12.5	23.1	6.1	12.3	1a
WF138	<b>ZCEW125CE</b>	HC844			■					1
WF589	<b>ZCET125SE</b>	CY9020		■			20.8	5.4	9.3	3a
WF141	<b>ZCEW125SE</b>	HC844			■					3
WF585	<b>ZCET150CE</b>	CY9020		■		15	28.3	7.59	14.9	1a
WF144	<b>ZCEW150CE</b>	HC844			■					1
WF590	<b>ZCET150SE</b>	CY9020		■			25.7	7.09	11.8	3a
WF147	<b>ZCEW150SE</b>	HC844			■					3
WF586	<b>ZCET160CE</b>	CY9020		■		16	28.8	7.45	15.4	1a
WF539	<b>ZCET160CE</b>	HC844			■					1a
WF591	<b>ZCET160SE</b>	CY9020		■			26.3	6.96	12.4	3a
WF540	<b>ZCET160SE</b>	HC844			■					3a
WF514	<b>ZCEW200CE</b>	HC844			■	20	35.4	8	20.1	1
WF515	<b>ZCEW200SE</b>	HC844			■		31.9	7	15.7	3
WF587	<b>ZCET250CE</b>	CY250	■			25	38.8		26	2
WF512	<b>ZCET250CE</b>	HC844			■					45.03
WF592	<b>ZCET250SK</b>	CY250	■				18.95		18.95	
WF513	<b>ZCET250SK</b>	HC844			■					
WF025	<b>CPMT080204</b>	HC844			■	0.4	7.94	2.38	7.94	5
WF034	<b>CPMT090308</b>	HC844			■	0.8	9.525	3.18	9.525	5
WF041	<b>CPMT120408</b>	HC844			■	0.8	12.7	4.76	12.7	5

■ = Available insert and grade combination